

Compli

**SEWAGE LIFTING STATIONS**



**PUMP TECHNICAL  
SERVICES LIMITED**



**THE SUBMERSIBLE PUMP SPECIALISTS**

MANUFACTURING | SALES | PROJECT DESIGN | INSTALLATION | MAINTENANCE AND REPAIRS

# Compli - the right lifting system for every application

## Single units



### Compli 300 E

Tank volume: 50 l  
Hmax 10.5 (m) | Qmax 29 (m<sup>3</sup>/h)  
Inlet heights: 180 mm  
Discharge branch: DN 80  
Dimensions: 445 x 525 x 525 mm  
(HxWxD)



### Compli 400

Tank volume: 64 l  
Hmax 7.0 (m) | Qmax 48 (m<sup>3</sup>/h)  
Inlet heights: 180 to 250 mm  
Discharge branch: DN 80/DN 100  
Dimensions: 528 x 728 x 575 mm  
(HxWxD)



### Compli 500

Tank volume: 117 l  
Hmax 20 (m) | Qmax 76 (m<sup>3</sup>/h)  
Inlet heights: variable  
Discharge branch: DN 80/DN 100  
Dimensions: 600 x 835 x 690 mm  
(HxWxD)

## Duplex units



### Compli 1000/Compli 1000 HL

Tank volume: 117 l  
Hmax 20 (m) | Qmax 76 (m<sup>3</sup>/h)  
Inlet heights: variable  
Discharge branch: DN 80/DN 100  
Dimensions: 600 x 835 x 690 mm  
(HxWxD)



### Compli 1200 HL

Tank volume: 350 l  
Hmax 18 (m) | Qmax 73 (m<sup>3</sup>/h)  
Inlet heights: variable 560-700 mm  
or rotatable 180 °  
Discharge branch: DN 80/DN 100  
Dimensions: 810 x 910 x 1010 mm  
(HxWxD)



### Compli 1500/Compli 2500 HL

Tank volume: 500 l/1000 l  
Hmax 50 (m) | Qmax 100 (m<sup>3</sup>/h)  
Inlet heights: 185/700 mm  
Discharge branch: DN 100  
Dimensions:  
820 x 910 x 1610 mm (HxWxD)  
820 x 1955 x 1610 mm (HxWxD)

## With cutting system



### Compli with cutting system 100

Tank volume: 38 l  
Hmax 21(m) | Qmax 17 (m<sup>3</sup>/h)  
Inlet heights: 180/250 mm  
Discharge branch: DN 32  
Dimensions: 400 x 450 x 619 mm  
(HxWxD)



### Compli with cutting system 1000

Tank volume: 117 l  
Hmax 21(m) | Qmax 17 (m<sup>3</sup>/h)  
Inlet heights: variable  
Discharge branch: DN 40  
Dimensions: 600 x 835 x 690 mm  
(HxWxD)

## Stainless-steel units



### Compli Stainless Steel

Tank volume: 270/540/900 l  
Hmax 16 (m) | Qmax 122 (m<sup>3</sup>/h)  
Inlet heights: 800 mm  
Discharge branch: DN 100  
Dimensions: on request

## Accessories for easy and safe installation



### Sluce valve

required for maintenance of the swing-type check valve according to EN standard - size DN 80 or DN 100



### Inlet gate valve

Made of PVC, size DN 100 or DN 150, with glued-in pipe sockets for quick and space-saving direct connection to the clamp-type inlet flange.



### Hand diaphragm pump

Hand pump for emergency purposes, for a delivery head of up to Hgeod 15 m

# Compli 300 – the smallest and lightest

The **Compli 300 E** is the smallest sewage lifting station in the compli series. Its very compact tank dimensions and the numerous connection options make it particularly versatile. It is specially designed for disposing of sewage from small residential units.

The powerful alternating current motor based on a sturdy annular housing made of grey cast iron, which ensures excellent stability and smooth running.

#### Areas of application:

Basement flats  
Granny annexes  
Apartments  
Small workshops

#### Inlet:

180 mm





› **EASY INSTALLATION**

- plug & play
- no electrician required
- simple assembly
- numerous connection options
- easy handling due to small tank dimensions and low weight

› **HIGH OPERATIONAL RELIABILITY**

- thanks to cast-iron support platform
- smooth running and low noise

› **EASY TO MAINTAIN**

- large cleaning aperture
- › Smart Home compatible

Type	Mat. no.	Free passage	Hmax [m]	Qmax [m <sup>3</sup> /h]
Compli 300 E	JP50076	50 mm	7.0	52

# Compli 400 - the classic solution for single-family homes

The **Compli 400** has been an integral part of wastewater disposal in single-family homes for decades. The submersible system reliably disposes of domestic wastewater even in areas that are prone to flooding.

Adapted to market requirements, the compli 400 now has a new design, improved technology, and even more convenient features.

The powerful wastewater pump rests on a stable cast iron ring, which ensures stability, smooth running, and a permanently sealed connection to the tank.

Thanks to a height-adjustable inlet socket, the inlet height can be adjusted to the height of the inlet pipe on site, as required.

The control unit included in the scope of delivery has also been improved and now features:

- an alarm that can be acknowledged with the push of a button
- a maintenance interval indicator
- a plug-in connection for an additional high-water alarm.

## Areas of application:

Single-family houses

## Inlet:

180 to 250 mm





#### ▶ EASY INSTALLATION

- height-adjustable clamp-type flange (stepless)
- variable discharge branch (DN 80 or DN 100)
- versatile connection options
- turnable swing-type check valve

#### ▶ INTEGRATED HYDRAULICS

- better flow behaviour
- lower weight
- no corrosion
- less blocking
- larger pump volume

#### ▶ CONTROL SYSTEM UPDATE

- maintenance interval indicator
- additional connection for an additional high-water alarm
- alarm acknowledgement

#### ▶ Smart Home compatible

Type	Mat. no.	Free passage	Hmax [m]	Qmax [m <sup>3</sup> /h]
Compli 400	JP50079	70 mm	7.0	48
Compli 400 E	JP50081	70 mm	7.0	48
Compli 400 with swing-type check valve	JP50080	70 mm	7.0	48
Compli 400 E with swing-type check valve	JP50082	70 mm	7.0	48

# Compli 500 - when a little more is needed

The **Compli 500** reliably disposes of larger volumes of wastewater and has a larger storage volume (117 l). As with all Compli systems, this unit has a user-friendly control unit to ensure reliable operation. Different motor outputs are available to meet different performance requirements.

Like the Compli 400 series, it is equipped with an improved control unit and now features:

- an alarm that can be acknowledged with the push of a button
- a maintenance interval indicator
- a plug-in connection for an additional high-water alarm.

#### Areas of application:

Single and two-family houses

#### Inlet:

**DN 100:** Inlet heights 180-205 mm (left), 250-300 mm (centre) and 290-340 mm (right), each steplessly variable

**DN 150/DN 50:** Inlet heights 180 mm (left), 275 mm (centre) and 315 mm (right)







▶ **SIMPLE ASSEMBLY**

- with flexible connection options
- pressure pipe options: DN80 or DN100
- ready to plug in
- with pre-installed swing-type check valve
- variable inlet heights for quickly adapting to the drainage situation on site

▶ **HIGH OPERATIONAL RELIABILITY**

- single unit with a large-volume tank for more storage volume in an emergency
- higher pumping capacity can be selected to suit the specific application
- cast, longitudinally-sealed cable inlets to protect the pump against moisture penetration
- guided float switch for reliable, clearly-defined switching points

- smooth, quiet running thanks to cast-iron support platform

▶ **EASY TO MAINTAIN**

- tank bottom optimised for inlets, with less cleaning required
- large cleaning aperture
- bolted impeller connection for quick maintenance

▶ **CONTROL SYSTEM UPDATE**

- maintenance interval indicator
- additional connection for an additional high-water alarm
- alarm acknowledgement

▶ **Smart Home compatible**

Type	Mat. no.	Free passage	Hmax [m]	Qmax [m <sup>3</sup> /h]
Compli 510/4 BW	JP50091	70 mm	7.0	52
Compli 515/4 BW	JP50092	70 mm	9.5	69
Compli 525/4 BW	JP50093	70 mm	5.0-11.0	56
Compli 525/2 BW	JP50094	70 mm	14.0	69
Compli 535/2 BW	JP50095	70 mm	20.5	85

# Compli 1000 HL for extra safeguards

## NOW WITH HIGHLOGO MICROPROCESSOR CONTROL UNIT

Multiple residential units or commercial buildings call for extra safeguards as well as more pumping capacity. This is why the **Compli 1000 and Compli 1000 HL** are duplex units, with two pumps on one tank. Either the wastewater is pumped by each pump alternately or, at peak loads, both pumps work together.

The new swing-type check valve made of high-tech compound plastic has a larger maintenance opening and offers special benefits. It dispenses with the need to dismantle the pump when carrying out maintenance or replacing the rubber flap.

The 10/4 BW, 15/4 BW and 25/4 BW submersible pumps have screwed, high-strength plastic impellers that can be easily dismantled for maintenance purposes.

The versions with a **HighLogo microprocessor control unit** offer special, convenient features, since for duplex units, in particular, even more attention is paid to safeguards. The many different functions can be selected via the intuitively operated rotary button and are shown on the large display.

With an optional accessory (GSM modem), faults can be sent by SMS and/or email to programmable receivers.

### Areas of application:

Hotels  
Cafés and restaurants  
Cinemas and theatres  
Apartment buildings

### Inlet:

**DN 100:** Inlet heights 180-205 mm (left), 250-300 mm (centre) and 290-340 mm (right), each steplessly variable

**DN 150/DN 50:** Inlet heights 180 mm (left), 275 mm (centre) and 315 mm (right)





**Now with the new  
HighLogo  
Microprocessor  
Control Unit**

▶ **SIMPLE ASSEMBLY**

- with flexible connection options
- height-adjustable inlets
- ready to plug in and easy to install
- duplex swing-type check valve with large maintenance opening
- reduced weight thanks to plastic inlet gate valve (accessory)

▶ **HIGH OPERATIONAL RELIABILITY**

- duplex unit with a large-volume tank for more storage volume in an emergency
- higher pumping capacity can be selected to suit the specific application

-available in two versions:

with tried-and-tested BasicLogo control unit or with modern HighLogo microprocessor control unit

▶ **HIGHLOGO MICROPROCESSOR CONTROL UNIT**

- alarm acknowledgement via push-button
- motor current monitoring
- compact housing
- operating hours meter
- event memory
- maintenance interval indicator
- pump switching cycles
- analogue level indicator

▶ Smart Home compatible

Type	Mat. no.	Free passage	Hmax [m]	Qmax [m <sup>3</sup> /h]
Compli 1010/4 BW E	JP50099	70 mm	7.0	52
Compli 1010/4 BW	JP50100	70 mm	7.0	52
Compli 1015/4 BW	JP50101	70 mm	9.5	69
Compli 1025/4 BW	JP50102	70 mm	11.0	56
Compli 1025/2 BW	JP50103	70 mm	14.0	69
Compli 1035/2 BW	JP50104	70 mm	20.5	85
Compli 1010/4 BW E HL	JP50105	70 mm	7.0	52
Compli 1010/4 BW HL	JP50106	70 mm	7.0	52
Compli 1015/4 BW HL	JP50107	70 mm	9.5	69
Compli 1025/4 BW HL	JP50108	70 mm	11.0	56
Compli 1025/2 BW HL	JP50109	70 mm	14.0	69
Compli 1035/2 BW HL	JP50110	70 mm	20.5	85

# Compli 1200 - for more storage volume

## NOW WITH NEW HIGHLOGO MICROPROCESSOR CONTROL UNIT

The **Compli 1200** with a storage volume of 350 l is the ideal solution when wastewater from several residential units or from commercial establishments needs to be disposed of. It is designed to ensure convenient handling, a space-saving set-up and easy installation and maintenance.

The new swing-type check valve made of high-tech compound plastic has a larger maintenance opening and offers special benefits. It dispenses with the need to dismantle the pump when carrying out maintenance or replacing the rubber flap.

The 10/4 BW, 15/4 BW and 25/4 BW submersible pumps have screwed, high-strength plastic impellers that can be easily dismantled for maintenance purposes.

The **HighLogo microprocessor control unit** is particularly convenient. For duplex units, in particular, even more attention is paid to safeguards. The many different functions can be selected via the intuitively operated rotary button and are shown on the large display.

With an optional accessory (GSM modem), faults can be sent by SMS and/or email to programmable receivers.

### Areas of application:

Commercial properties  
Hospitals  
Apartment buildings  
Hotels  
Restaurants

### Inlet:

The rear **inlet (DN 150)** can be mounted with a fitting (not included) so that it is height-adjustable (inlet heights 560-700 mm) and rotatable (180°).



**Now with the new  
HighLogo  
Microprocessor  
Control Unit**

▶ **SIMPLE ASSEMBLY**

- with flexible connection options
- height-adjustable inlet
- ready to plug in and easy to install
- duplex swing-type check valve with large maintenance opening
- reduced weight thanks to plastic inlet gate valve (accessory)

▶ **HIGH OPERATIONAL RELIABILITY**

- duplex unit with a large-volume tank for more storage volume in an emergency
- higher pumping capacity can be selected to suit the specific application

▶ **HIGHLOGO MICROPROCESSOR CONTROL UNIT**

- alarm acknowledgement via push-button
- motor current monitoring system
- compact housing
- operating hours meter
- event memory
- maintenance interval indicator
- pump switching cycles
- analogue level indicator

▶ **Smart Home compatible**

Type	Mat. no.	Free passage	Hmax [m]	Qmax [m <sup>3</sup> /h]
Compli 1210/4 BW HL	JP50118	70 mm	7.0	52
Compli 1215/4 BW HL	JP50119	70 mm	9.5	69
Compli 1225/4 BW HL	JP50120	70 mm	11.0	56
Compli 1225/2 BW HL	JP50121	70 mm	14.0	69
Compli 1235/2 BW HL	JP50122	70 mm	20.5	85

# Compli 1500/ Compli 2500 - for complex applications

## NOW WITH NEW HIGHLOGO MICROPROCESSOR CONTROL UNIT

For large volumes of industrial or municipal wastewater, a particularly large tank is required. With a total volume of 1000 l and correspondingly powerful non-clogging pumps, the Compli 2500 is the largest lifting station. Depending on the requirements, the units are supplied with one tank (Compli 1500 with 500 l, see illustration) or two tanks (Compli 2500).

The **HighLogo microprocessor control unit** is particularly convenient. For duplex units, in particular, even more attention is paid to safeguards. The many different functions can be selected via the intuitively operated rotary button and are shown on the large display.

With an optional accessory (GSM modem), faults can be sent by SMS and/or email to programmable receivers.

### Areas of application:

Commercial properties  
Hospitals  
Sports stadiums/event centres  
Hotels  
Apartment buildings

### Inlet:

**DN 150** right, left and rear,  
inlet height 700 mm

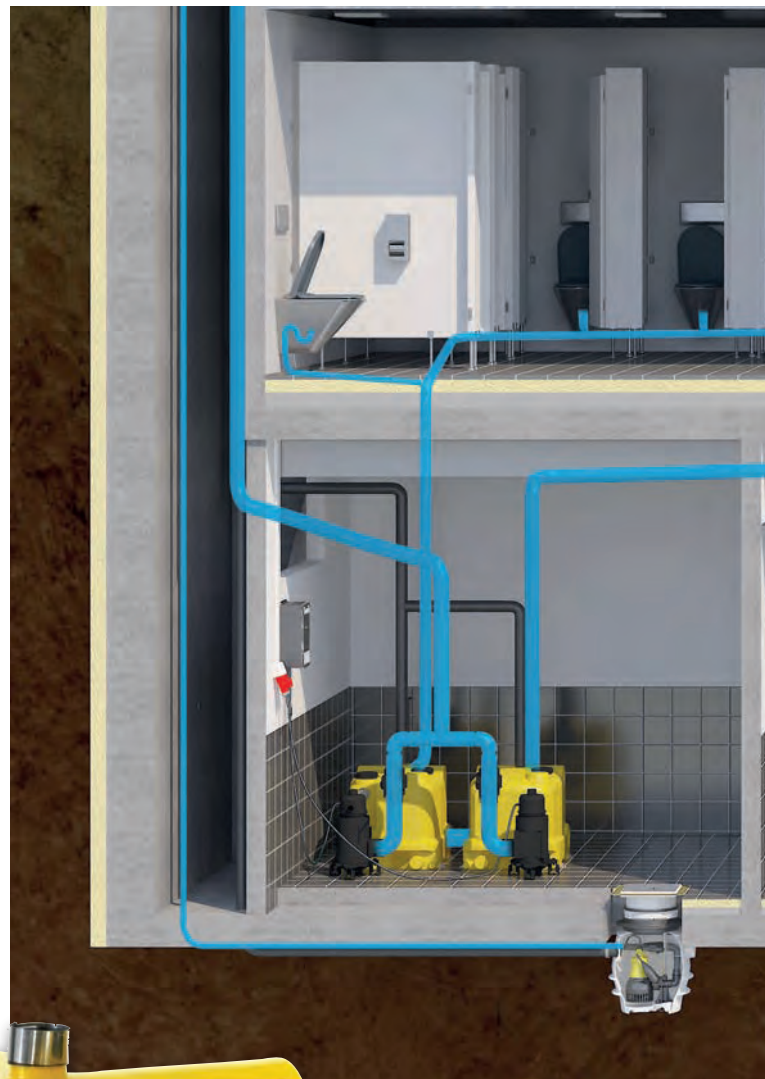

**Now with the new  
HighLogo  
Microprocessor  
Control Unit**

▶ **SIMPLE ASSEMBLY**

- ready to plug in and easy to install
- selectable inlet options

▶ **HIGH OPERATIONAL RELIABILITY**

- 500 l or 1000 l tank volume
- robust PE tank
- powerful wastewater pumps
- large free passage, up to 100 mm

▶ **HIGHLOGO MICROPROCESSOR CONTROL UNIT**

- alarm acknowledgement via push-button
- motor current monitoring system
- compact housing
- operating hours meter
- event memory
- maintenance interval indicator
- pump switching cycles
- analogue level indicator

▶ Smart Home compatible

Type - 1 tank	Mat. no.	Type - 2 tanks	Mat. no.	Free passage	Hmax [m]	Qmax [m <sup>3</sup> /h]
Compli 1525/4 C1 HL	JP50123	Compli 2525/4 C1 HL	JP50133	100 mm	10.0	104
Compli 1535/4 C1 HL	JP50124	Compli 2535/4 C1 HL	JP50134	100 mm	12.0	103
Compli 1555/4 C5 HL	JP50125	Compli 2555/4 C5 HL	JP50135	100 mm	18.0	100
Compli 1575/4 C5 HL	JP50126	Compli 2575/4 C5 HL	JP50136	100 mm	20.0	100
Compli 1575/4 B6 HL	JP50127	Compli 2575/4 B6 HL	JP50137	70 mm	22.5	91
Compli 1535/2 B2 HL	JP50128	Compli 2535/2 B2 HL	JP50138	70 mm	18.0	102
Compli 1555/2 B2 HL	JP50129	Compli 2555/2 B2 HL	JP50139	70 mm	22.0	96
Compli 1575/2 B5 HL	JP50130	Compli 2575/2 B5 HL	JP50140	70 mm	31.0	104
Compli 15100/2 B5 HL	JP50131	Compli 25100/2 B5 HL	JP50141	70 mm	41.0	91
Compli 15200/2 B6 HL	JP50132	Compli 25200/2 B6 HL	JP50142	70 mm	50.0	95

# Compli - with Multicut cutting system

The **Compli with MultiCut Grinder Pumps** is specially designed for cases where wastewater has to be pumped through long, small-diameter pressure pipes to the next sewer or where the delivery head is extremely large (several floors).

It is available as single and duplex units.

Areas of application for the compli with Multicut cutting system:

Campsites  
Toilet cars/trailers  
Smaller buildings  
Shops

Inlet, compli 1000 with cutting system:

**DN 150/DN 50:** Inlet heights 180, 275 and 315 mm

**DN 100:** Inlet heights 180-340 mm







▶ **SPECIAL FEATURES**

- with Multicut cutting system
- 38 l and 117 l tank volumes
- for small-diameter pressure pipes
- large delivery heads

▶ **SIMPLE ASSEMBLY**

- ready to plug in and easy to install
- height-adjustable inlets
- clamp-type inlet flange made of plastic
- pre-installed swing-type check valve

▶ **HIGH OPERATIONAL RELIABILITY**

- duplex unit with a large-volume tank for more storage volume in an emergency
- higher pumping capacity can be selected to suit the specific application

▶ **CONTROL SYSTEM UPDATE FOR SINGLE UNITS**

- maintenance interval indicator
- additional connection for an additional high-water alarm

▶ Smart Home compatible

Type	Mat. no.	Free passage	Hmax [m]	Qmax [m <sup>3</sup> /h]
Compli 108/2 ME	JP50088	7 mm	16.0	16
Compli 108/2 M	JP50089	7 mm	16.0	16
Compli 120/2 M	JP50090	7 mm	8.0-24.0	16
Compli 508/2 ME	JP50096	7 mm	16.0	16
Compli 508/2 M	JP50097	7 mm	16.0	16
Compli 520/2 M	JP50098	7 mm	2 8.0-24.0	16
Compli 1008/2 ME	JP50112	7 mm	16.0	16
Compli 1008/2 M	JP50114	7 mm	16.0	16
Compli 1020/2 M	JP50115	7 mm	2 8.0-24.0	16

# Compli in stainless steel

For applications where special fire protection regulations apply, we offer individually configured sewage lifting stations with stainless-steel tanks.

The stainless steel tanks have freely accessible connections with a clamp-type inlet flange for easy installation. To ensure time-saving maintenance, a cleaning opening is provided at the top, and the pumps can be easily replaced

Areas of application:

Underground train stations

Airports

Multi-storey car parks



- ▶ high-quality stainless-steel tank
- ▶ tank volume on request
- ▶ selectable inlet positions
- ▶ Smart Home compatible



# The right size

## Compli 1000

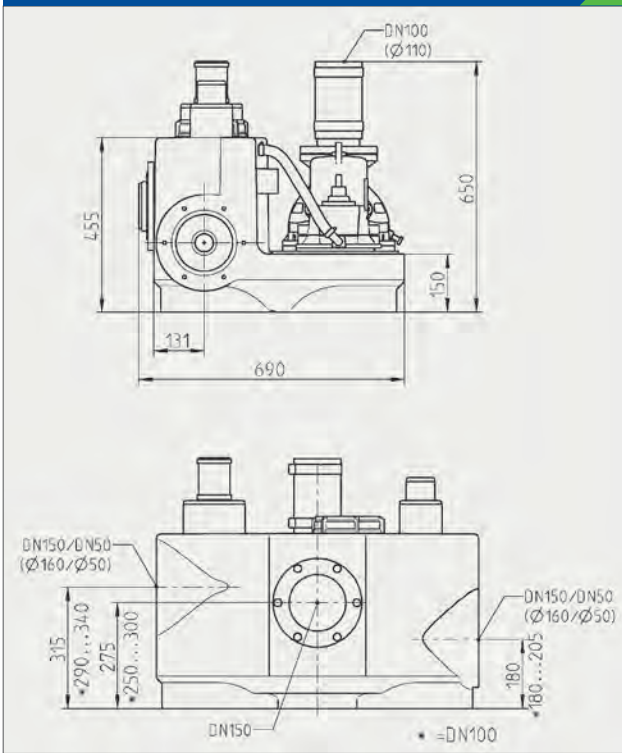

## Compli 1200

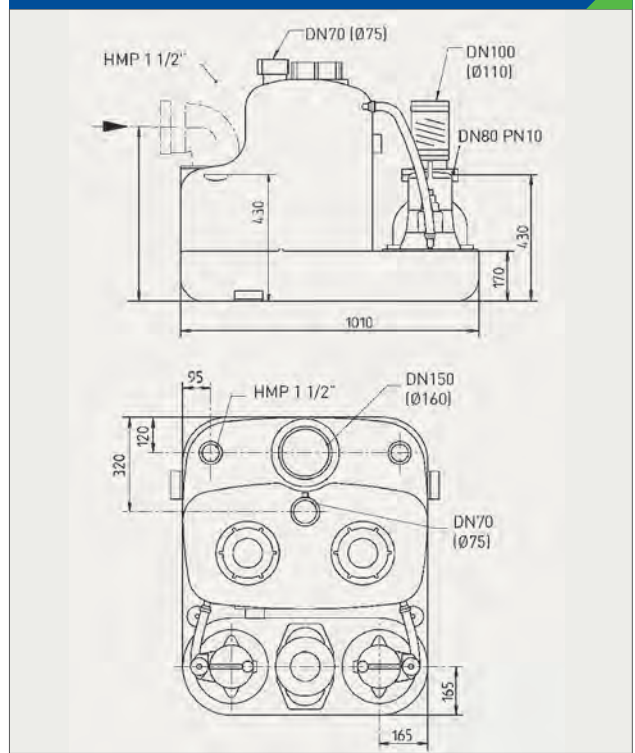

## Compli 1000 with cutting system

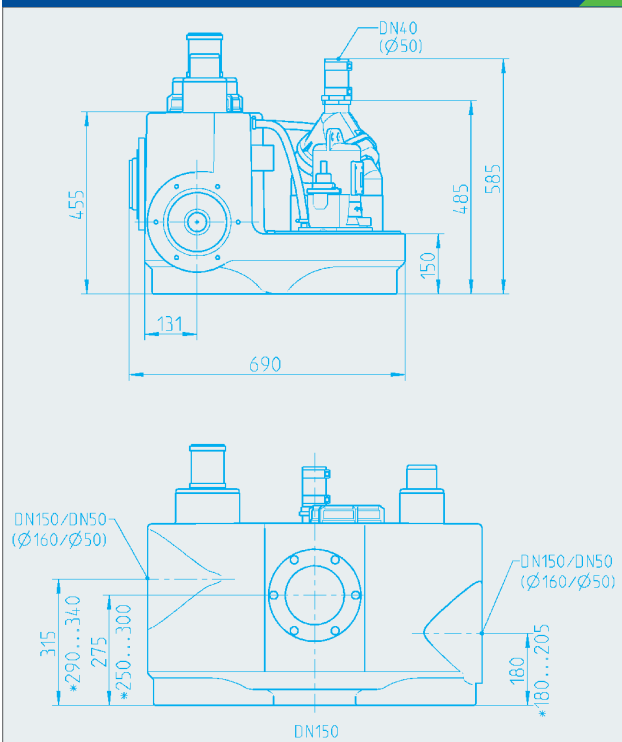

## Compli 1500 | 2500

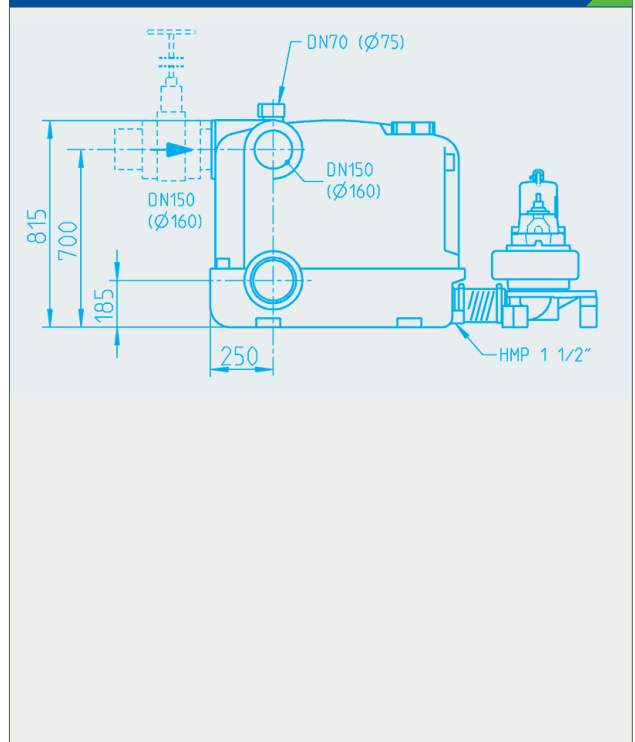

# Proper maintenance

Have your sewage lifting station serviced regularly by qualified personnel. By doing so, you not only comply with the standards of EN 12056 Part 4, but also secure the following benefits:

- ▶ prevent cost-intensive repairs
- ▶ high operational reliability
- ▶ low breakdown rate
- ▶ long service life
- ▶ highly efficient system



▶ Easy removal of the pump unit



▶ Checking the impeller



▶ Checking and cleaning the swing-type check valve



▶ Cleaning the tank